



# ALLTAC CONCENTRIC TGSI TIS-010

## INDICATOR DETAILS

<b>RANGE</b>	CONCENTRIC
<b>MATERIAL</b>	STAINLESS STEEL
<b>FINISH</b>	MACHINED

## FEATURES

CONCENTRIC 10 RING DESIGN  
SIMPLISTIC RECOGNISED DESIGN  
304 OR 316 STAINLESS STEEL  
AS/NZS 1428.4 COMPLIANT  
SUITABLE FOR INTERNAL AND EXTERNAL  
VARIOUS STEM OPTIONS

## TESTING (PERFORMED BY CSIRO)

AS/NZS 4586 APPENDIX A  
WET PENDULUM 45: W

AS/NZS 4586 APPENDIX D  
OIL WET RAMP TEST: R12

AS/NZS 1428.4  
WET & DRY LUMINOUS REFLECTANCE: 31.0 - 34.8

## PRODUCT DIMENSIONS

<b>TOP OF DOME</b>	25mm
<b>BASE OF DOME</b>	35mm
<b>HEIGHT OF DOME</b>	5mm
<b>STEM LENGTH</b>	VARIOUS



**ALLTAC**

**ALLTAC are manufacturers and distributors of quality Australian products**

info@alltac.com.au  
www.alltac.com.au

Unit 39, 1 Kingston Rd  
Heatherton VIC 3202

1300ALLTAC  
1300 255 822

Allsafe products can be installed by our licensed contractors throughout Australia and overseas.

# ALLTAC ALLSTAR TGS1 TIS-010

## FINISH

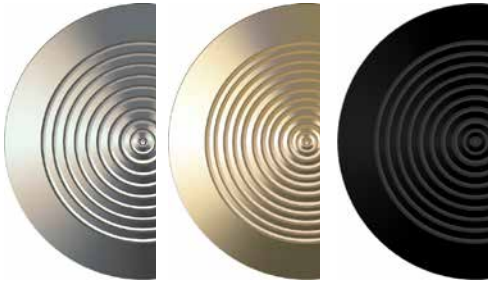

STAINLESS

BRASS

BLACK

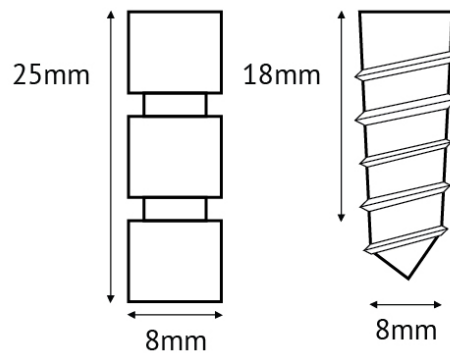
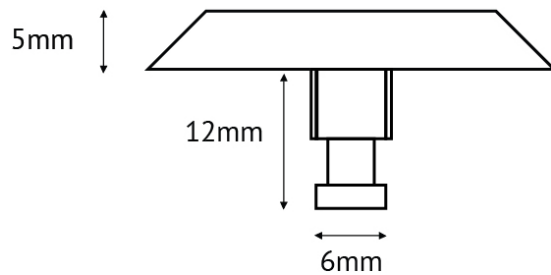
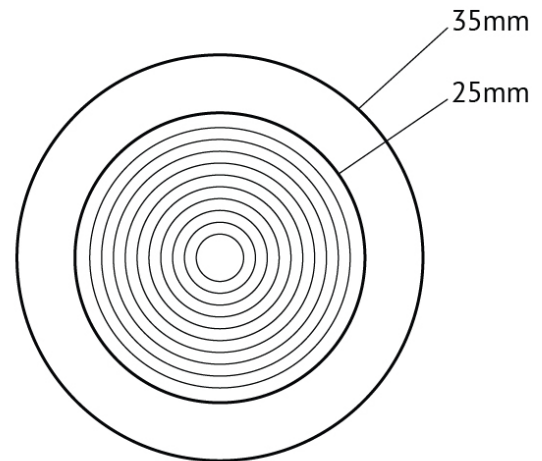

ALLTAC are manufacturers and distributors of quality Australian products

info@alltac.com.au  
www.alltac.com.au

Unit 39, 1 Kingston Rd  
Heatherton VIC 3202

1300ALLTAC  
1300 255 822

Allsafe products can be installed by our licensed contractors throughout Australia and overseas.